

# Pneumatic tools

## Air knives and Cooling tubes

### Air knife : AK200

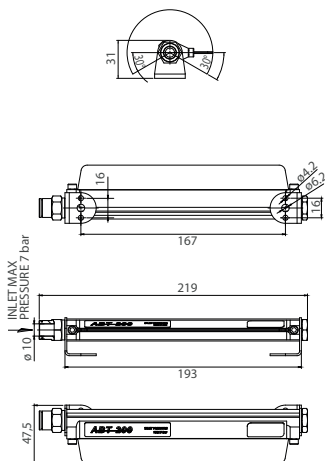

#### GENERAL FEATURES - AK200

Materials	Anodized aluminium
Air supply port	Fitting Ø-10
Fastening	Integrated feet
Blade length	170 mm
Slots' size	0,05 mm on each side
Air supply pressure	Max 1-7 Bar
Optional magnetic support	

#### PERFORMANCES AND CONSUMPTION TABLE

Pressure [Bar]	CONSUMPTION [NI/min]	THRUST [at 200 mm in g]
1	765	42
2	978	238
3	1360	595
4	1573	722
5	1955	1105
6	2380	1490
7	2663	1900