

VP-SS-SERIE

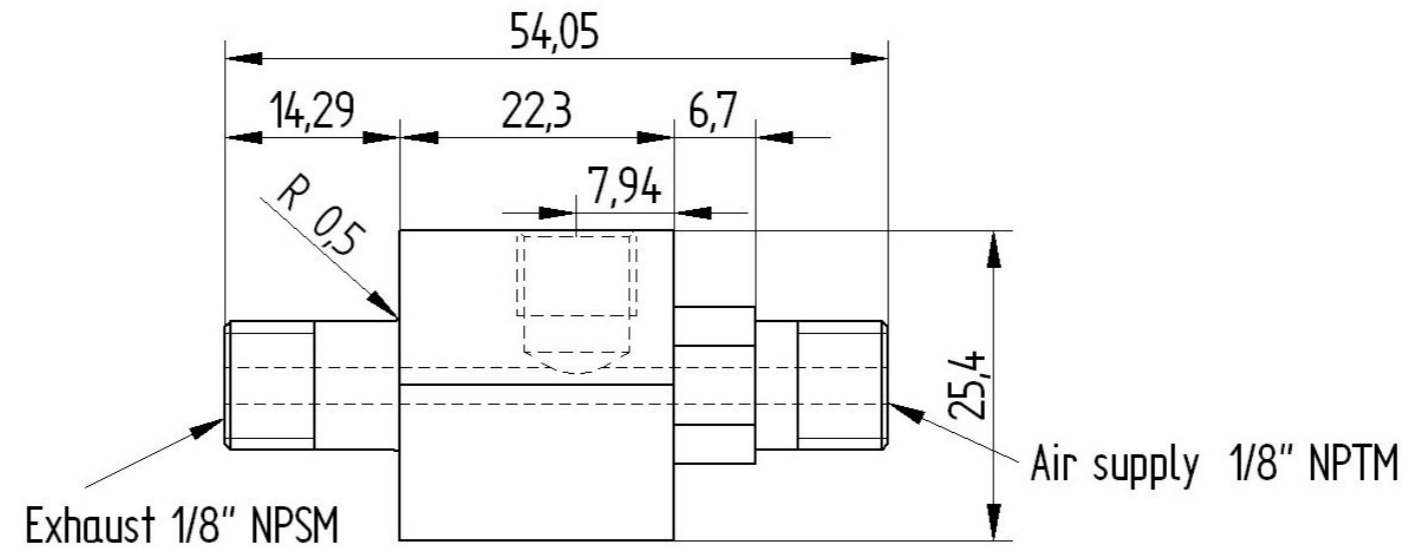

SPECIFICATIES · specifications

Max.vacuüm niveau <i>max vacuum degree</i>	[Mbar]
Max. zuigvolume <i>max suction air flow</i>	[nl/min]
Perslucht verbruik <i>air flow consumption</i>	[nl/min]
Werkdruk <i>supply pressure</i>	[bar]
Persluchtaansluiting <i>supply port</i>	
Vacuüm aansluiting <i>vacuum port</i>	
Gewicht <i>weight</i>	[Kg]
Materiaal <i>material</i>	

	VP-HAVR038HSS	VP-HAVR062HSS	VP-HAVR093HSS	VP-HAVR093MSS	
Max.vacuüm niveau	-930	-950	-950	-620	
Max. zuigvolume	4,5	11,8	28,2	34,7	
Perslucht verbruik	8,7	23,1	53,6	28,2	
Werkdruk	5,2	5,2	5,2	5,2	
Persluchtaansluiting	1/8 NPTM	1/8 NPTM	1/8 NPTM	1/8 NPTM	
Vacuüm aansluiting	1/8 NPTM	1/8 NPTM	1/8 NPTM	1/8 NPTM	
Gewicht	0,435	0,435	0,435	0,435	
Materiaal	RVS	RVS	RVS	RVS	

BESTELLEN · HOW TO ORDER

RVS ejecteurpomp *Generates vacuum*

VP-HAVR038HSS      VP-HAVR062HSS      VP-HAVR093HSS      VP-HAVR093MSS