



## Specification

Medium	Air
Operating pressure range	0.2~1 MPa
Proof pressure	1.5 MPa
Ambient temperature	-5~+60°C (No freezing)
Lubrication	Not required
Cushion	With rubber cushion pad

Type of cylinder	Operation type	Standard stroke	Magnet	Weight
	Direct stopper (Double acting)	ø20-10	○	192 g
		ø32-20	○	720 g
		ø50-30	○	1850 g

## Piping diagram

Single acting

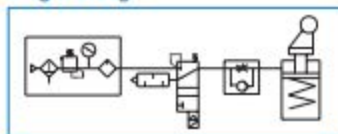

Double acting

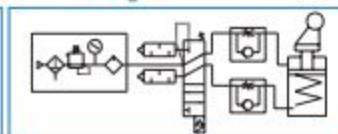

## Pallet control stopper type

### Shock absorber built-in

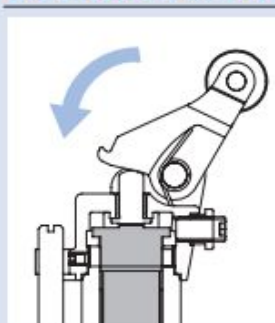

Absorbs the shock when the carried object stops, and stops the object softly on the right Position. There is an adapter between the lever and shock absorber, which straightens the inclined load on the lever and transmits it to the lever.

### Lever lock mechanism

With this optional feature, the carried object is not pushed back by the lever. Also the Object returns to the right position after being lifted up. The lock is released by supplying air and lowering the rod.

### Stopper mechanism

Guide bar equipped for fixing the direction of the roller lever.

### Light aluminum

Main cylinder part, shock absorber, and roller lever are integrated in the aluminum die cast body. The best cylinder for the light and space-saving conveyor line.

### Free pass mechanism

Setting the pass-plate on the lever holder, the lever is fixed in the OFF position. Use the optional feature when the carried object needs to pass over the cylinder.



### Solenoid valve and sensor switch

Magnet-sensing sensor switch is available for MS\*\* Reed or "solid state" switches with LED is fixed, not need to adjust the position, 5/2 solenoid Valve can be directly mounted on the cylinder.



ø20-10

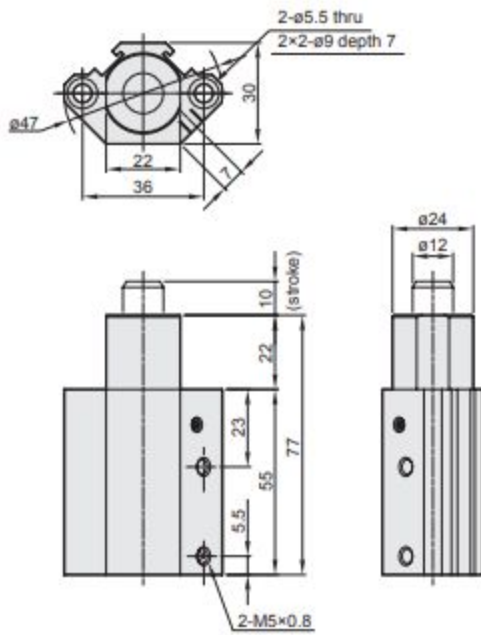

ø32-20

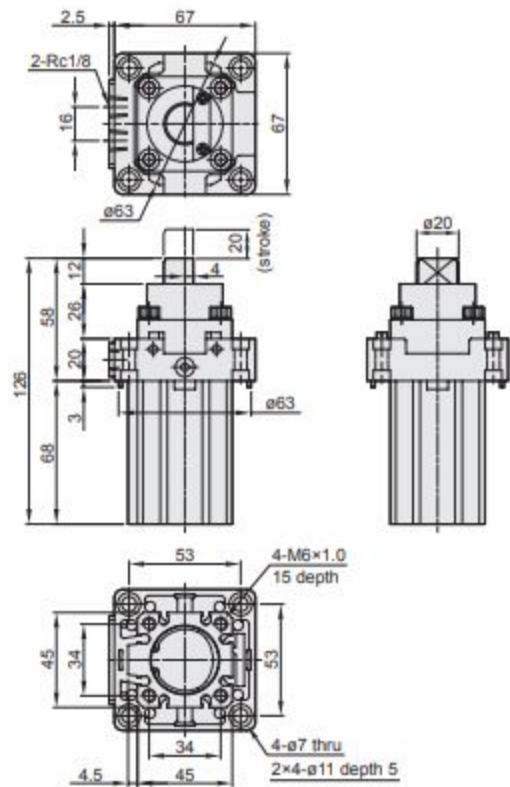

ø50-30

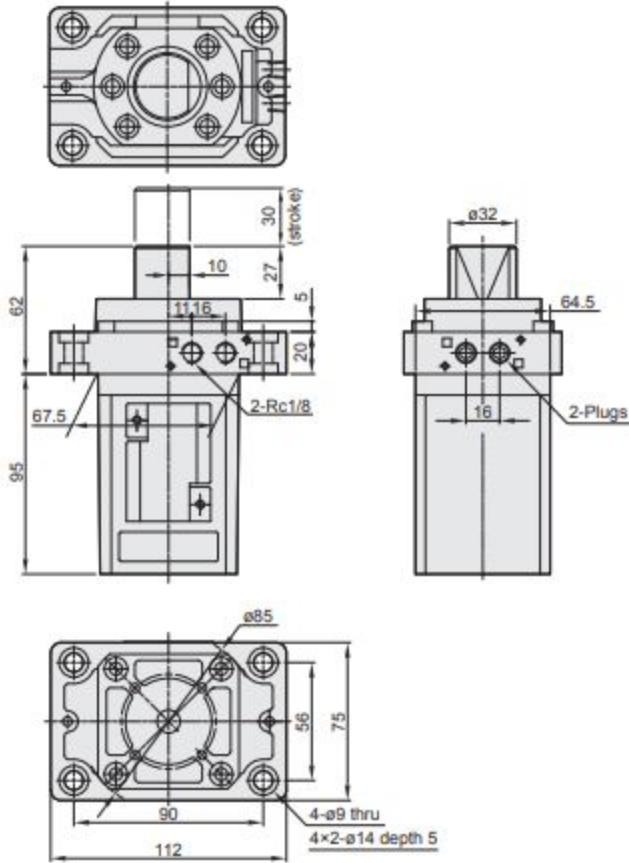

## Capacity

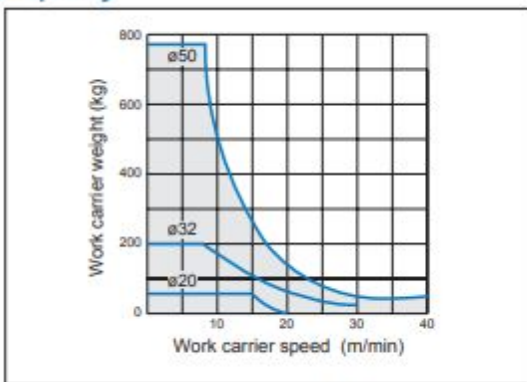

## Normal lateral load

